



# JOINT UNIVERSEL LARGE ET TRES LARGE TOLERANCE EN FONTE DUCTILE PN16 MAXIFIT

## Présentation :

Pièce de liaison avec tolérance pour tuyaux

Construction Fonte ductile GJS 500

Revêtement époxy 250 microns minimum

Matériels éprouve hydroliquement PN10 & 16

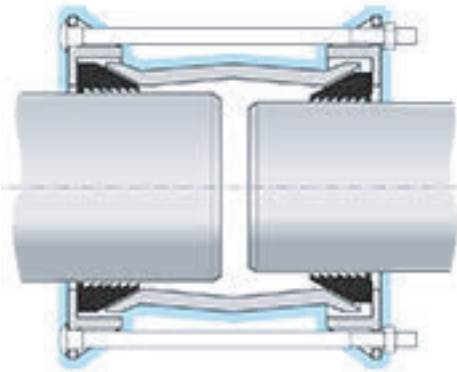

DN	DE mini	DE maxi	Boulonnerie	Poids KG
50	60	72	2-160-120	3.00
60	68	86	4-M12X180	4.50
80	84	106	4-M12X180	5.00
100	106	130	4-M12X180	6.10
125	125	140	4-M12X180	8.00
150	159	184	4-M12X180	9.00
150	176	188	4-M12X180	9.20
175	184	198	4-M14X250	14.00
200	218	245	4-M14X250	15.00
200	234	255	4-M14X250	15.20
225	242	262	4-M14X250	17.00
250	265	280	6-M16X350	18.00
250	284	297	6-M16X305	18.00
300	315	331	6-M16X370	27.00
300	334	361	6-M16X370	27.00
400	394	433	6-M16X400	42.00
500	500	532	6-M16X450	62.00